

PLEASE READ this sheet prior to assembly to familiarise yourself with the various stages of construction. Carefully open the pack supplied and check the contents against the parts and fittings check list.

Do not destroy any of the packaging until you are certain that you have all the necessary parts for the assembly.

Please ensure that the packaging is disposed of in a safe environmentally friendly way.

CAUTION: There are small components used in the construction of this unit. These loose items should be kept away from young children during assembly, to avoid the danger of choking.

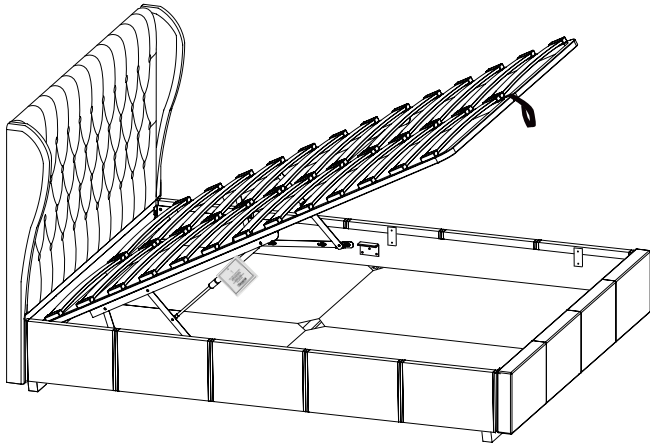

IMPORTANT: BEFORE STARTING TO ASSEMBLE THE BED - PLEASE READ THESE INSTRUCTIONS CAREFULLY.



An instructional video of the Operation of the Ottoman Lift Up system is available via YouTube using the following address: https://youtu.be/hyq4zm7h_yU

Parts Identification

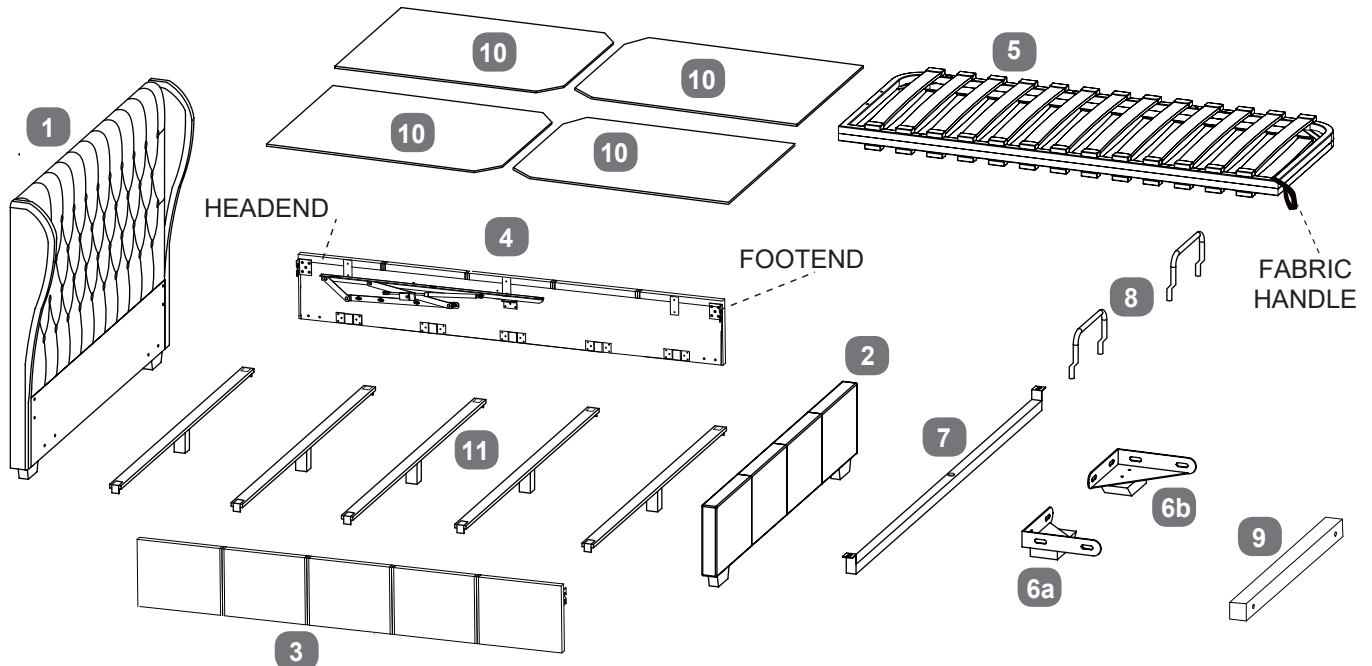

Parts Checklist

Ref.	Description	Qty	Ref.	Description	Qty
1	Headboard	1	7	Cross Bar	1
2	Footboard	1	8	Mattress Stoppers	2
3	Side Rail - Left	1	9	Slat Frame Support Rail (wood)	1
4	Side Rail - Right	1	10	Base Boards	4
5	Metal Slat Frame	1	11	Base Board Support Rails (wood)	5
6a&6b	Angle Brackets with Leg	2 Prs			

Fittings Checklist

HARDWARE NEEDED FOR BED ASSEMBLY (PACK A)

Code	Description	Qty	Code	Description	Qty
A	Bolts (M8x30mm) for fitting side rails (3&4) and to headboard & footboard (1&2)	x24	D	Allen Key (for M8 bolt)	x1
B	Spring Washers (for M8 bolts)	x24	F	Bolts (M8x50mm) for fitting Slat Frame Support Rail (9) to Footboard (2)	x2
C	Flat Washers (for M8 bolts)	x26			

HARDWARE FOR FITTING METAL SLAT FRAME (PACK B)

Code	Description	Qty	Code	Description	Qty
B	Spring Washers (for M8 bolts)	x6	G	Nuts (for M8 slat frame bolts)	x6
C	Flat Washers (for M8 bolts)	x18	H	Flange Lock-Nuts (M8) for gas-lift pistons	x2
E	Spanner (for M8 nut)	x1	J	Bolts (M8x20mm) for fitting Metal Plates (K) and Cross Bar (7) to Metal Slat Frame (5)	x6
F	Bolts (M8x50mm) for fitting Metal Slat Frame (5) to slat frame support bars	x6	K	Metal Plates for Slat Frame	x2

Additional Tools Required

No Additional Tools Required

Care & Maintenance

In the unlikely event of missing or damaged parts, please contact your retailer. Please have this guide at hand quoting the part code reference numbers shown when requesting spare or replacement parts.

General Hints & Tips



Please retain your assembly instruction and tools provided for future use. Periodically check that all bolts are still tight.

Assembly requires two persons.



1.5 Hrs

Approximate time to assemble this product



When they are supplied and are part of the assembly of this bed, ensure that the barrel nuts are fitted the correct way so the hole in the nut is facing towards the intersecting hole in the panel.

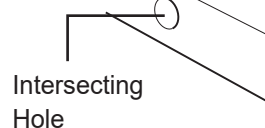

We recommend the bed is assembled in the room it shall be located in.

Bed Assembly - Use Pack 'A'

Stage
1

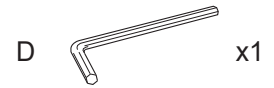
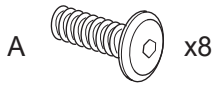

Fit two sets of bolts (A), spring washers (B), and flat washers (C) to the holes in the headboard (1) as shown.

Note: Do not tighten fully but leave 10mm protruding as in the diagram.

Fit the side panels (3 & 4) to the headboard locating the brackets behind the flat washers.

Fit the other two sets of bolts through the brackets into the central pair of holes.

Loosely screw in the bolts but do not tighten them 100% yet.

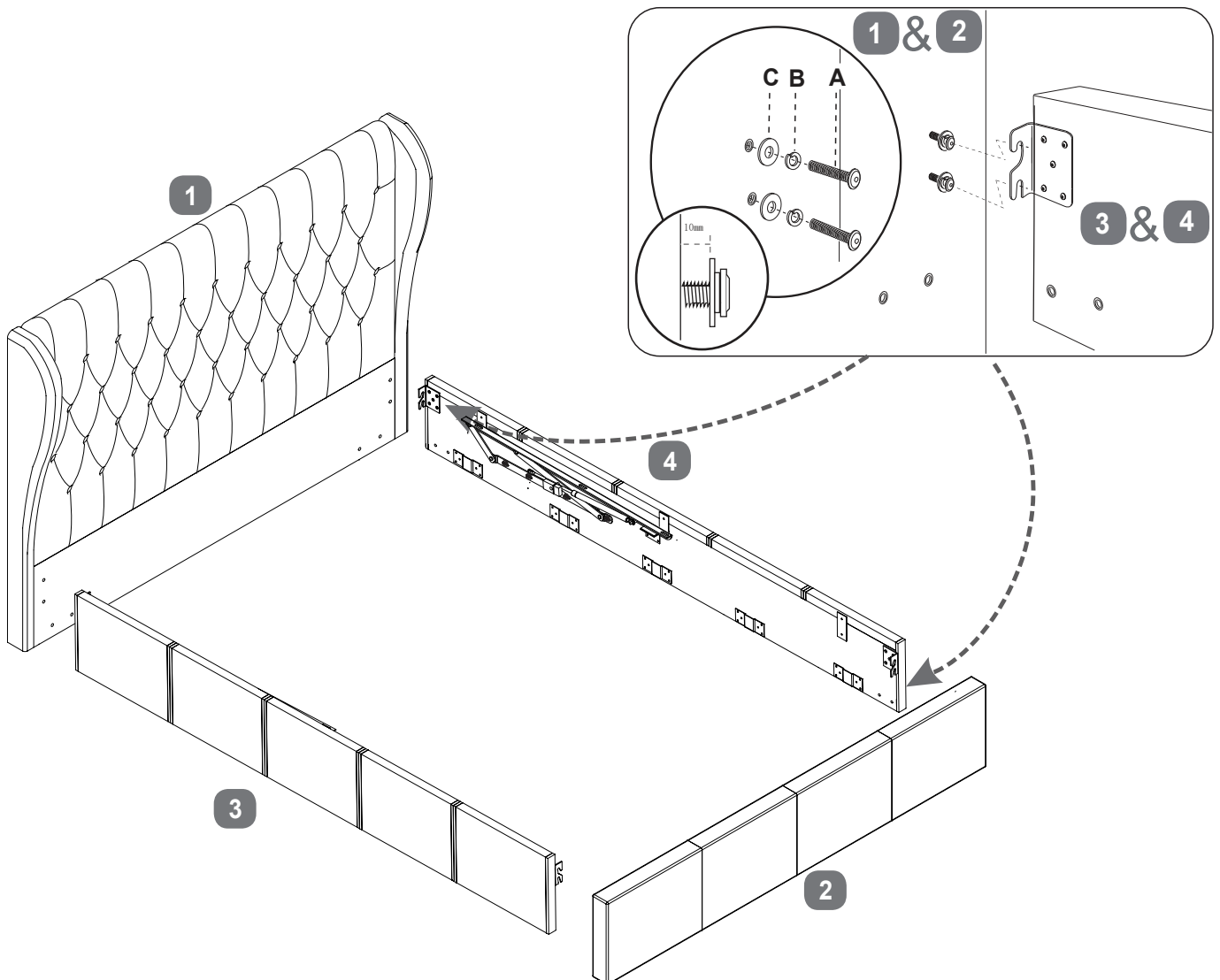

Bed Assembly - Use Pack 'A'

Stage
2



Fit the two angle brackets with leg (6a&6b) loosely screwing the bolts (A), spring washers (B) & flat washers (C) into the threaded inserts in the corners of headboard & footboard (1&2) and the side rails (3&4).

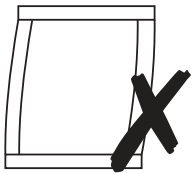
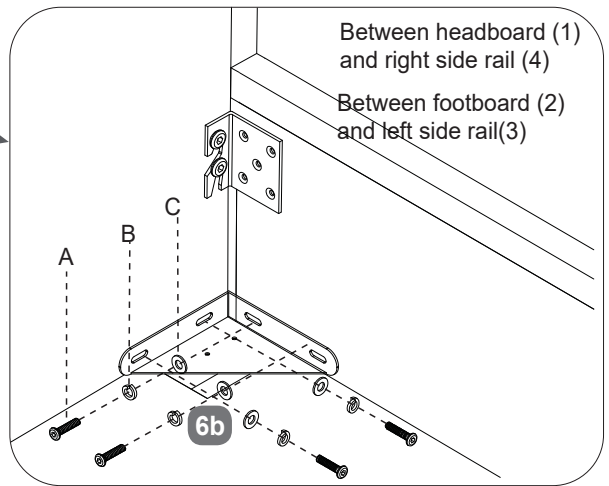
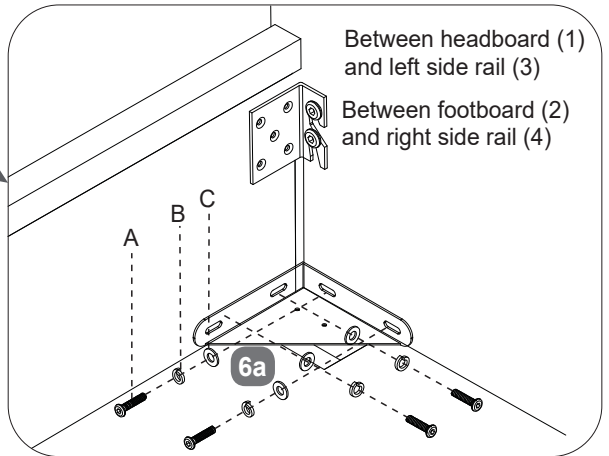
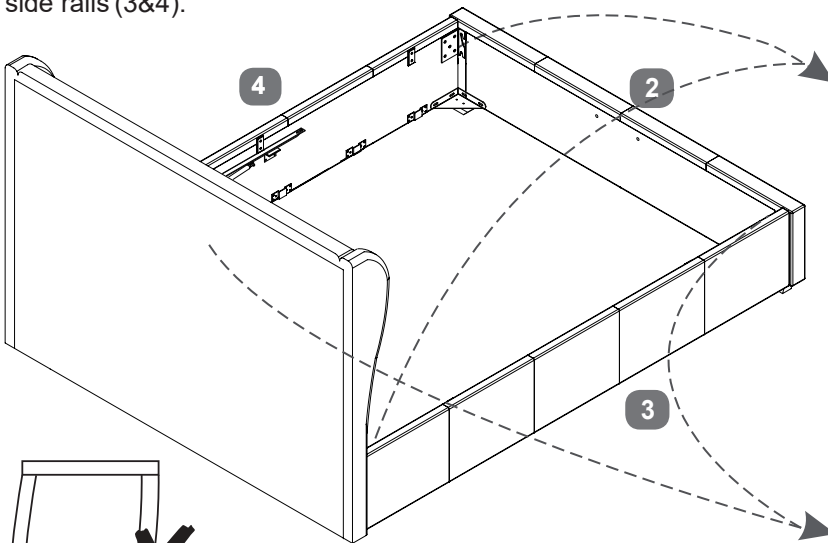

Make certain the bed is squared up as shown in the diagram then tighten all bed assembly bolts 100%.

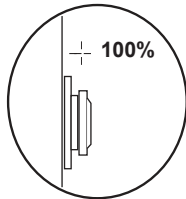
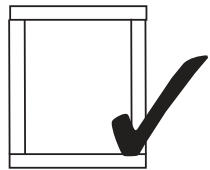

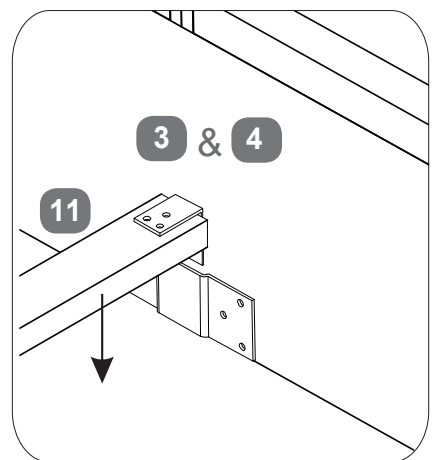
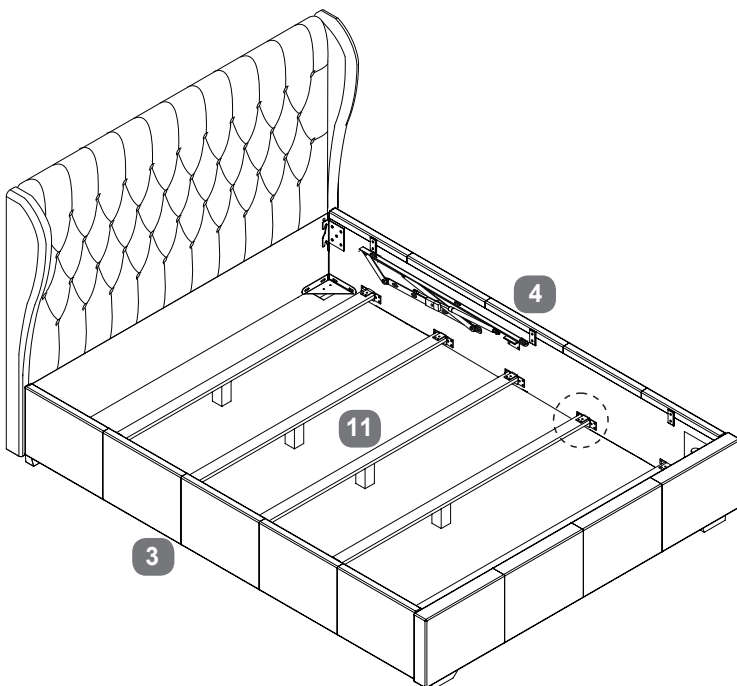

Stage
3

Fit the base board support rails (11) to both side panels.
IMPORTANT: Be careful not to scratch the PU or fabric when slotting the wooden supports into the side rail brackets.



Fit base boards - Use Pack 'A'

Stage
4

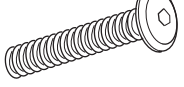
C  x2 D  x1 F  x2

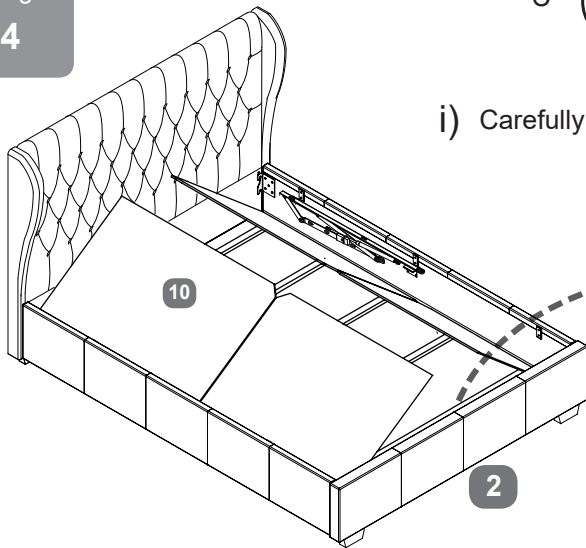

i) Carefully fit Base Boards (10).

ii) Fit slat frame support rail (9) to baseboard using two bolts (F) & flat washers (C).
Using Allen Key (D) tighten 100%.

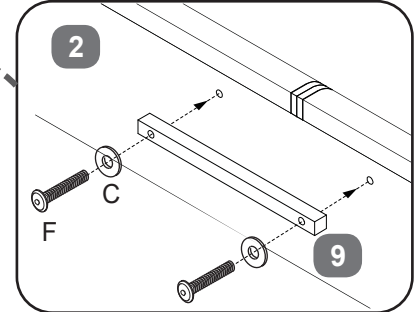

Assembling Slat Frame - Use Pack 'B'

Stage
5

C  x6 D  x1 J  x6 K  x2

i) Fitting position for cross Bar (7) is clearly labeled. Pass bar through Metal Slat Frame (5) between first & second slat. Carefully open the frame.

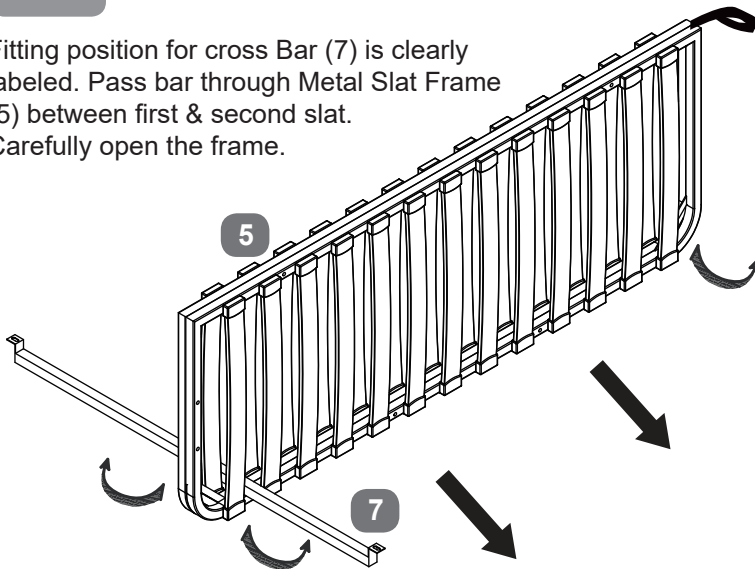

iii) Using four sets of bolts (J) & flat washers (C) fit two pieces of the metal plate (K) into threaded inserts on top of the frame. Using Allen key (D), tighten all six bolts 100%.

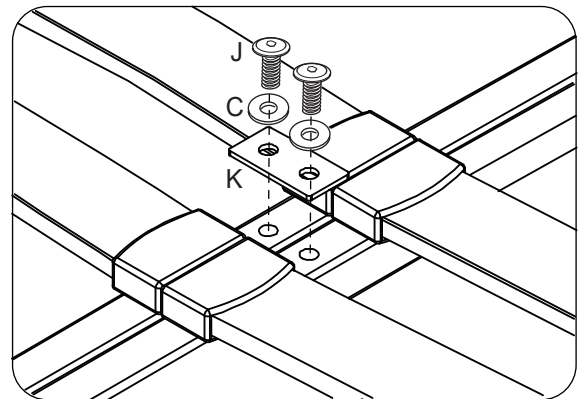

ii) Ease the plates on top of the cross bar (7) onto top of the slat frame sides and loosely fit two sets of bolts (J) & flat washers (C) through the plates into the threaded inserts. Do not tighten yet.

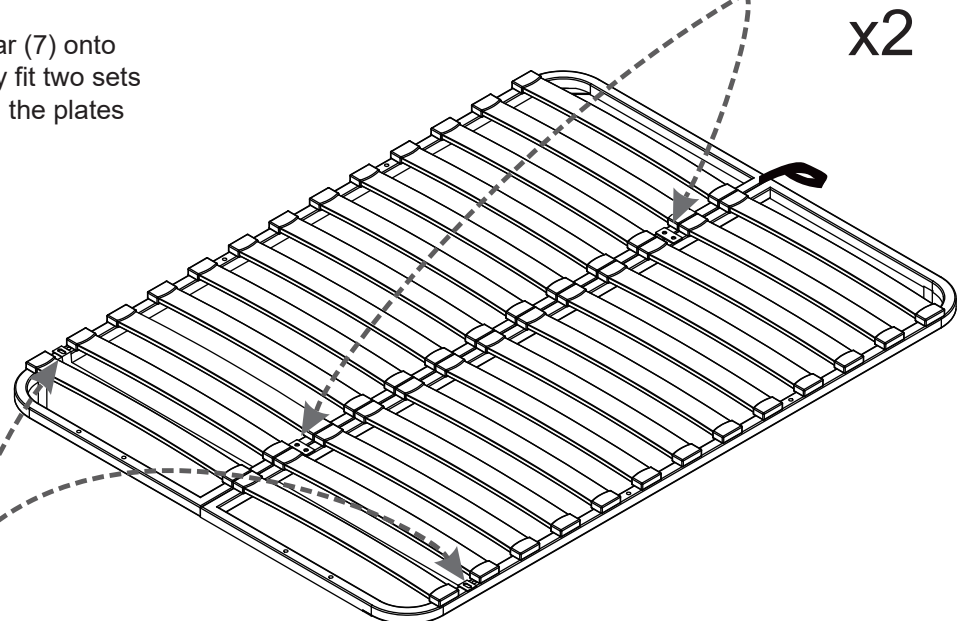
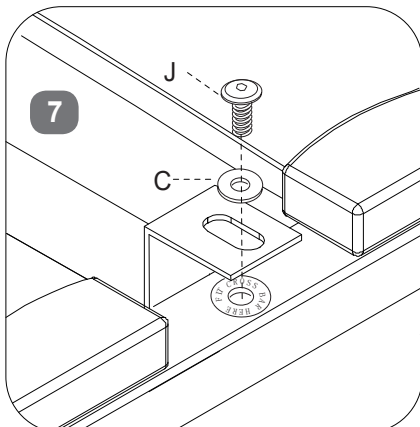

Fitting Slat Frame - Use Pack 'B'

Stage
6

B  x6

C  x12

D  x1

E  x1

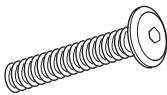
F  x6

G  x6

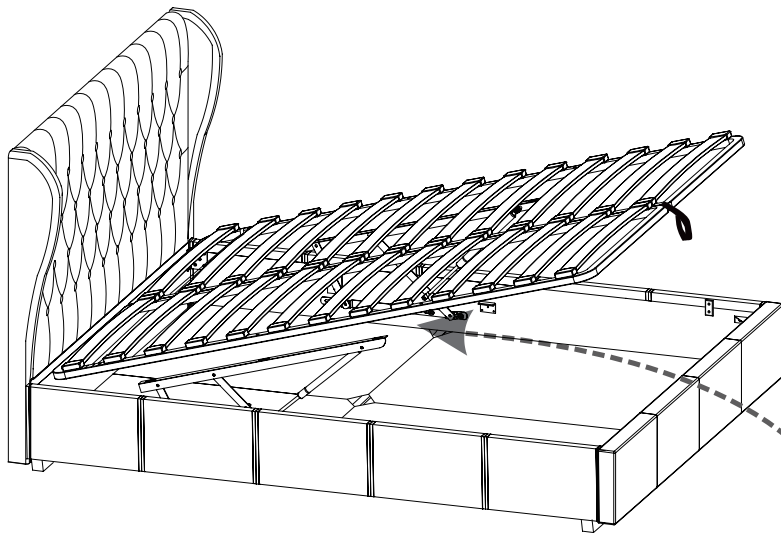
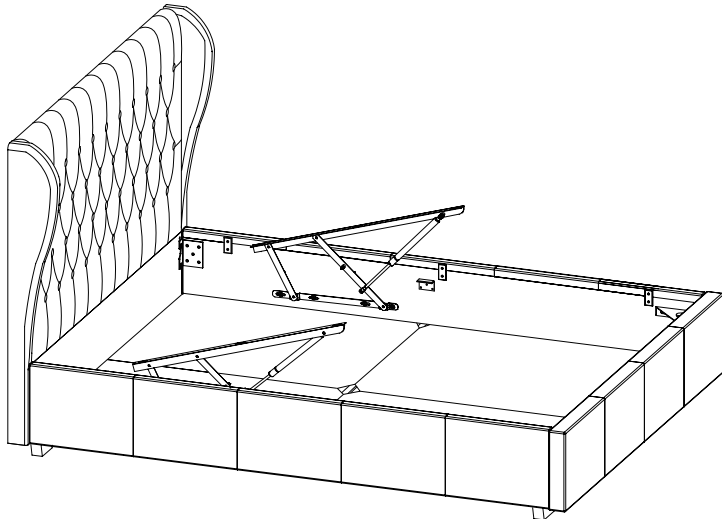

i) UN-TIE THE ONE MECHANISM, AND TAKE OUT THE BLOCK

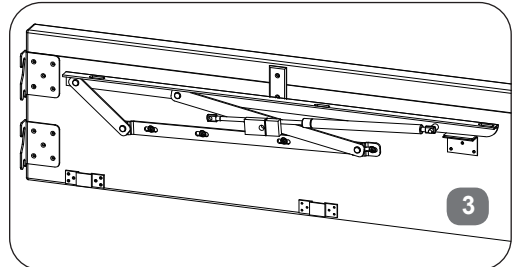

ii) HOLD THEM FORWARD

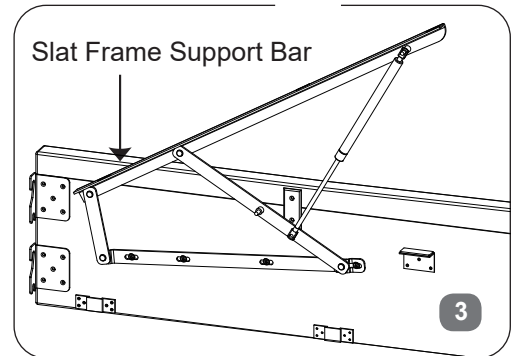

iii) With help from your assistant, lift slat frame (5) onto slat frame support bars aligning first set of holes on slat frame with first set of holes in support bars (nearest to headboard).

iv) Using three bolt sets on each side (F), (C), (B) & (G), fix slat frame to the support bars but do not tighten fully.

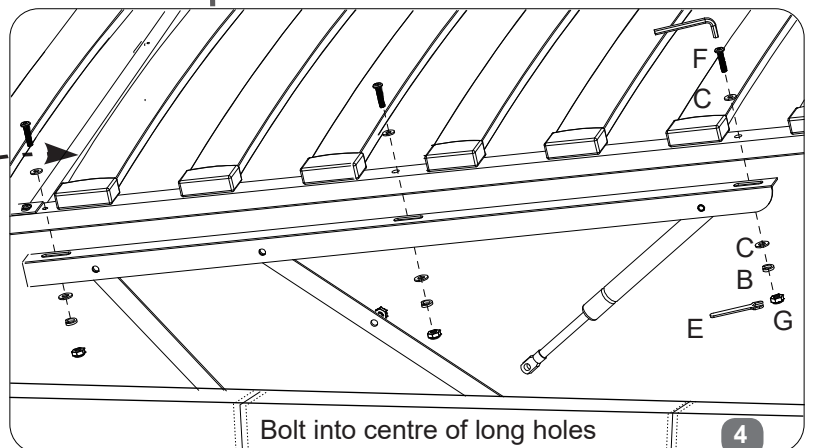

Fitting Slat Frame - Use Pack 'B'

Stage

7



Carefully lay frame down making sure there is an even gap all round as in the sketch.

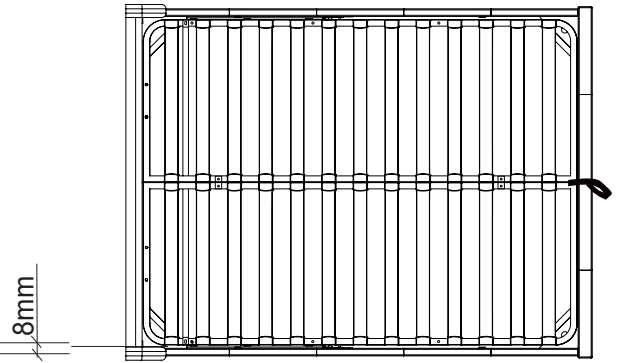
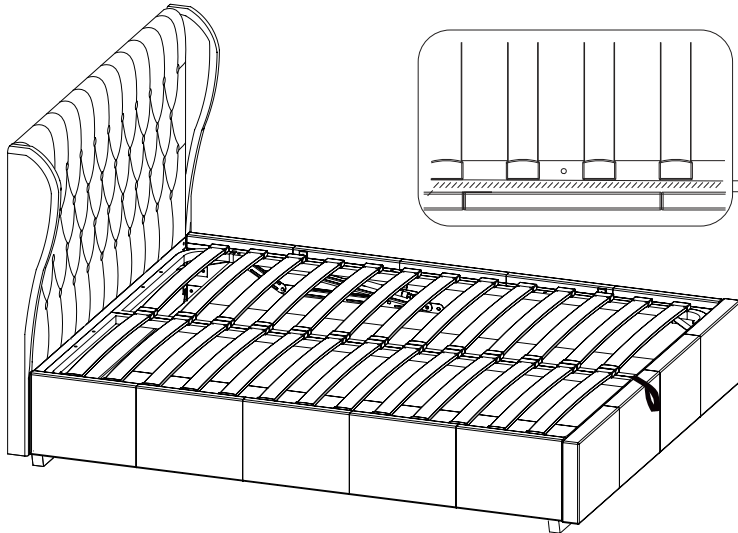

Hold frame securely then tighten all six bolt sets 100% using spanner (E) & Allen key (D).

Stage

8

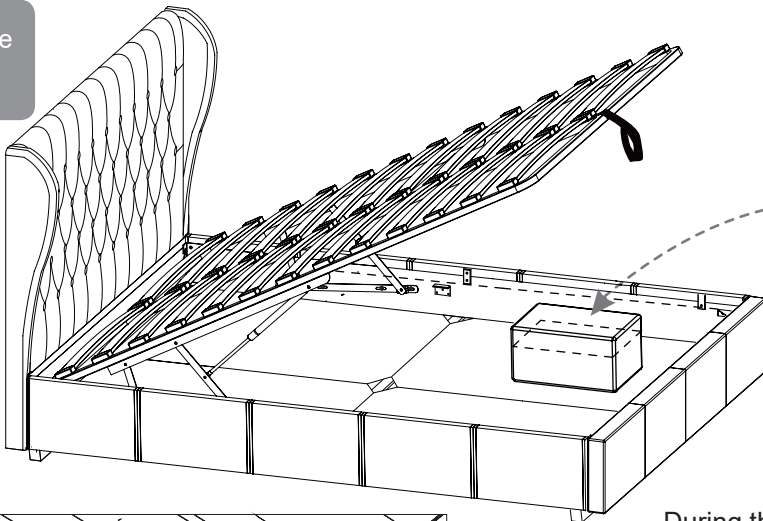
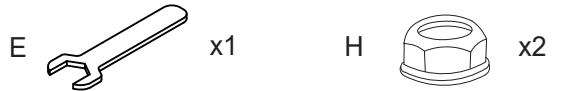

Note: Be very careful what you store under the bed - the top of an item, like a suitcase or a box must not touch the slats or they may be damaged. Maximum storage height is 185mm.

During this next step, the assistant should hold up the slat frame.

On side panels (3&4) slide gas-lift piston stems (X) onto the axes (Y) then fit the flange lock-nuts (H).

Tighten nuts with spanner (E) - BUT DO NOT over-tighten. A small gap is left so stems can move freely - this is important - see sketch below.

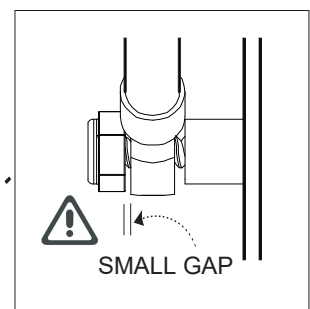
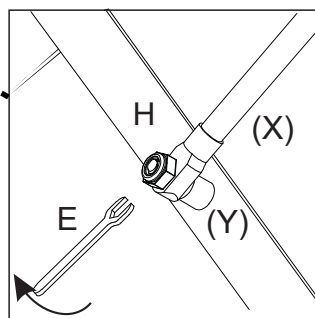
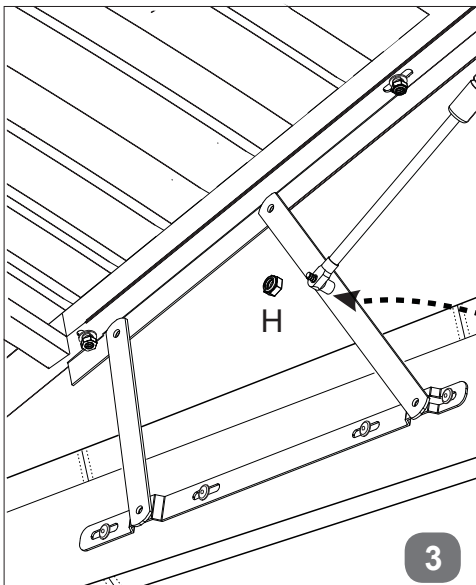

Push x2 Mattress Stoppers (8) into metal frame, they should go all the way through the upper & lower metal sections.

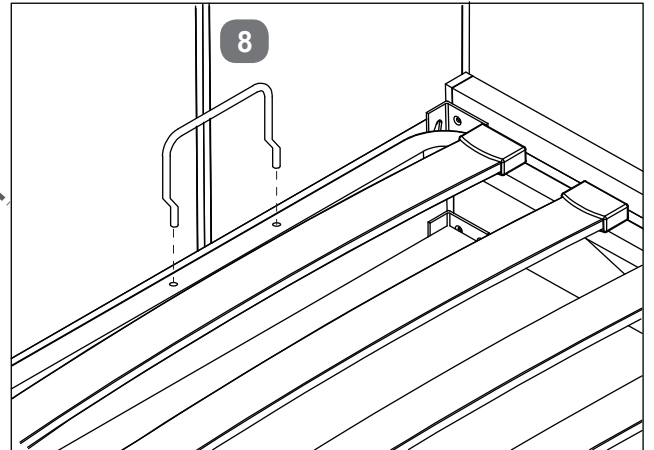
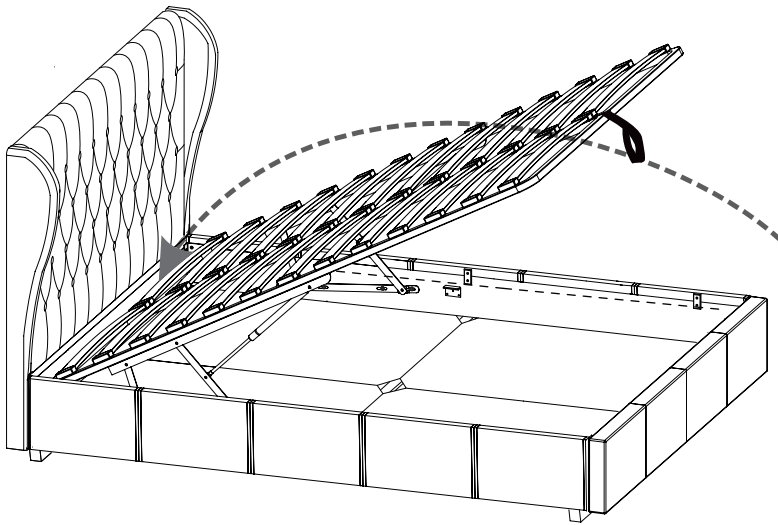

NOTE: Before moving the slat frame, place the mattress on the slats. Without a mattress in place, the speed of movement is quick and may cause injury. Carefully lower the frame with the hand-strap ensuring the frame sides are aligned with the side panels; there should be an even gap on each side. If not aligned, check bed is still square (see Stage 2) and if it is, but gaps are still not even, re-align as in Stage 7.

Depending on the weight of the mattress, the rising speed will vary so be careful until you get used to the speed. Always use the strap to lift or lower the frame - keep fingers well away from the moving parts.

When fully assembled and the mattress in position, please raise & lower the ottoman 4/5 times to ensure the gas pistons are fully lubricated.